

QK-CE220RLX CONTROL BOARD FOR SINGLE-PHASE / THREE-PHASE MOTORS

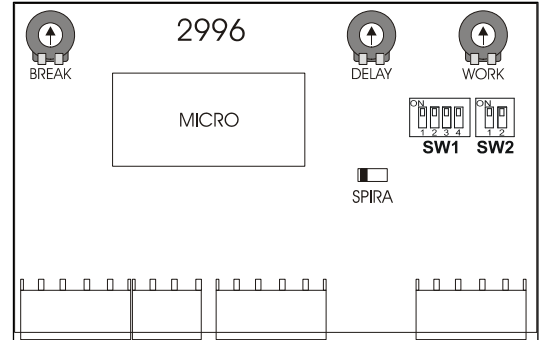
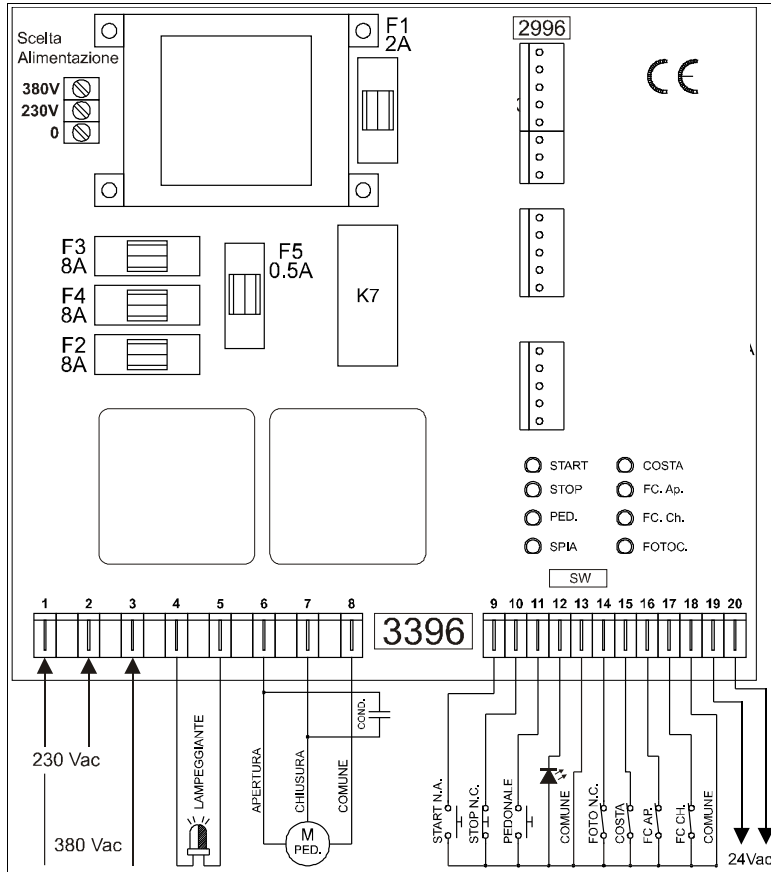

GENERAL ADVICE

QK-CE220RLX is a control board used for automation of heavy duty sliding gates. Suitable for a connection with a clock (timer) which can be connected to the start single input for timely controlled openings / closings. QK-CE220RLX control board is in compliance with the following directives: EMC 89/336/CEE, 92/31/CEE, BT 73/23/CEE e 93/68/CEE.

TECHNICAL FEATURES

Dimensions	260 x 210 x 100 mm IP55
Absorbed power	3W
24V fuse (F1)	2A
230V fuse (F2, F3, F4)	8A
Flashing lamp fuse (F5)	0,5A
Operating temperature	Da -20°C a +50°C
Motor relay contacts	16 A

ADVICES AND SUGGESTIONS FOR INSTALLATION

ATTENTION:

It is necessary to respect the polarity of the phases in the 230V a.c. connection (connector 1 = phase, connector 2 = neutral).
The n. c. contacts (limit switches, photocells and stop push button) if not used, must be connected to the common (connector 13) using bridges.

CONNECTIONS TABLE

1 - 2 ALIMENT.	230 Vac 50Hz mains power supply (1 phase, 2 neutral)	12 - 13 SPIA	Opened gate lamp / courtesy lamp output (see dip switch).
1 - 2 - 3 ALIMENT.	380 Vac three-phase 50Hz mains power supply	14 - 18 FOTO	Photocell input (n.c. contact). It stops and reverses the motor and it is only enabled during closing.
4 - 5 FLASH	Flashing light output (fixed). 230 Vac max 100 W	15 - 18 COSTA	Safety edge input (n.c. contact). It stops and reverses for 10cm the motor and it is only enabled during opening.
6 - 7 - 8 M	230/380 Vac 1 KW Max 1 HP motor output (7 close, 8 common, 6 open)	17 - 18 FC AP.	Opening limit switch input (n.c. contact).
9 - 13 START	Start signal (n.o. contact). During opening and closing it stops and reverses.	16 - 18 FC CH.	Closing limit switch input (n.c. contact)
10 - 13 STOP	Stop signal (n.c. contact). It always stops the motor. If pushed during pause it disables the automatic closing.	19 - 20 ALIMENT.	24 Vac 500mA accessories power supply
11 - 13 PED.	Pedestrian start signal (n.o.contact). It performs the partial opening adjustable by means of delay trimmer.	21 - 22	Not used
380 230 0	Mains voltage selection: 230 Vac 0 - 230 380 Vac 0 - 380	23 - 24	Not used

FINAL TESTING

- ◆ Check the connections of the motor bearing in mind that at first start up the motor should open.

SETTING THE DIP-SWITCHES

ATTENTION: The dip switches should be programmed when the control board is switched off.

	ON	OFF	
SW1	1	Slide gate mode	Not used
	2	Courtesy lamp mode enabled (90 seconds).	Opened gate lamp mode enabled.
	3	Condominium mode enabled. It doesn't accept start signals during opening. If a start signal is given during pause, the pause time gets reset and the gate closes.	Condominium mode disabled
	4	Automatic closing enabled.	Automatic closing disabled.
SW2	1	Not used	Not used
	2	Electric lock release function enabled	Electric lock release function disabled

WORKING TIME SETTING:

- 1) Make sure that the dip switch SW1 - 1 is on.
- 2) Adjust the WORK trimmer to modify the working time. It is possible to set it from 4" to 90".
- 3) It is possible to use the pedestrian opening (partial opening), adjustable by means of DELAY trimmer (from 2" to 15").

AUTOMATIC CLOSING TIME SETTING (PAUSE TIME):

- 1) Make sure that the dip switch SW1 - 4 is on.
- 2) Adjust the BREAK trimmer to modify the automatic closing pause time. It is possible to set it from 4" to 90".

OPEN ONLY AND CLOSE ONLY FUNCTION SETTING

Inserting a diode in the SPIRA connector, considering the polarity, it is possible to assign to the START button the OPEN ONLY function and to the PEDESTRIAN start button the close only function. Step-by-step function would then be disabled

RADIO RECEIVER CONNECTION

For the connection of the radio receiver refer to the user manual of the QK-R02.



1095 Budapest, Mester u. 34. **1141 Budapest, Fogarasi út 77.**
Tel.: *218-5542, 215-9771, 215-7550, Tel.: *220-7940, 220-7814, 220-7959,
216-7017, 216-7018 Fax: 218-5542 220-8881, 364-3428 Fax: 220-7940
Mobil: 30 940-1970, 20 949-2688 Mobil: 30 531-5454, 30 939-9989

E-mail: delton@delton.hu Web: www.delton.hu

www.kaputnyitunk.hu